

404570. MACHINESTELVOET VOLLEDIG PA 30% GLASVEZELVERSTERKT MAX 20°; BASCULEREND

Basis : PA 30% glasvezelversterkt uitgespaard

404571 : met antislipbasis TPE voorzien van zelfklevende strip.

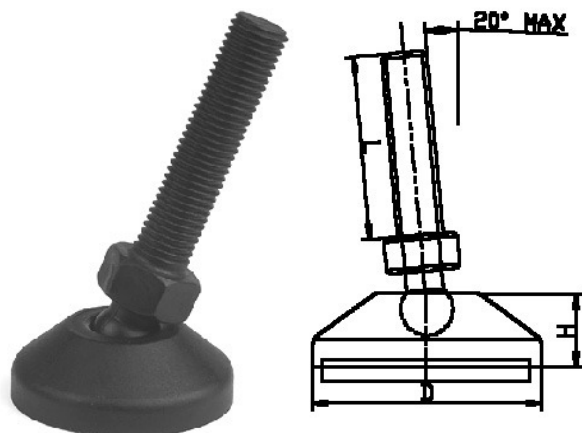

Artikelcode	D	H		Lengte	Bel. Nom.	Max. Kort
404570.050160700.000	50	40	M16	70	100 kg	500 kg
404570.050200700.000	50	40	M20	70	100 kg	500 kg
404570.050201200.000	50	40	M20	120	100 kg	500 kg
404570.060160700.000	60	40	M16	70	100 kg	500 kg
404570.060200700.000	60	40	M20	70	100 kg	500 kg
404570.060201200.000	60	40	M20	120	100 kg	500 kg
404570.080160700.000	80	40	M16	70	100 kg	500 kg
404570.080200700.000	80	40	M20	70	100 kg	500 kg
404570.080201200.000	80	40	M20	120	100 kg	500 kg
404570.100160700.000	100	40	M16	70	100 kg	500 kg
404570.100200700.000	100	40	M20	70	100 kg	500 kg
404570.100201200.000	100	40	M20	120	100 kg	500 kg